



JOHN EDMONDSON HIGH SCHOOL

Assessment Notification

Faculty: Industrial Arts Course: Industrial Technology - Timber Year: 10

Assessment Task: End Table

Assessment Weighting: 35% Due: Term 2 Week 2

Date: 10TT2.1 Mr. Singh (06/05/2024), 10TT1 (08/05/2024) 10TT 2.2 Mr. Dass (08/05/2024),

Task Type: Hand in Task In Class Task Practical Task

Outcomes assessed (NESA)
IND5-2 applies design principles in the modification, development and production of projects IND5-5 selects, interprets and applies a range of suitable communication techniques in the development, planning, production and presentation of ideas and projects IND5-1 identifies, assesses, applies and manages the risks and WHS issues associated with the use of a range of tools, equipment, materials, processes and technologies IND5-3 identifies, selects and uses a range of hand and machine tools, equipment and processes to produce quality practical projects IND5-9 describes, analyses and uses a range of current, new and emerging technologies and their various applications
Task Description/Overview
End Table Design Folio and Practical Production Progress
Detailed Assessment Task Description
A. End Table Design Folio B. Practical Production Progress

Assessment Criteria		
Grade	Description	Mark Range
Outstanding (O)	The student has an extensive knowledge and understanding of the content and can readily apply this knowledge. In addition, the student has achieved a very high level of competence in the processes and skills and can apply these skills to new situations.	90-100
High (H)	The student has a thorough knowledge and understanding of the content and a high level of competence in the processes and skills. In addition, the student is able to apply this knowledge and these skills to most situations.	80-89
Sound (S)	The student has a sound knowledge and understanding of the content and has achieved a good level of competence in the processes and skills.	60-79
Basic (B)	The student has a basic knowledge and understanding of the content and has achieved a basic level of competence in the processes and skills.	30-59
Limited (L)	The student has an elementary knowledge and understanding in a few areas of the content and still required further work to achieve competence in the processes and skills.	0-29

Satisfactory completion of courses

A course has been satisfactorily completed, when the student has:

- Followed the course developed/endorsed by the NSW Educational Standards Authority (NESA)
- Applied himself/herself with diligence and sustained effort to the set tasks and experiences provided in the course.
- Achieved some or all of the course outcomes

Year 10 Industrial Technology – Timber

End Table Design Folio **&** **Practical Production Progress**

Assessment Outcomes

A Student:

IND5-2 applies design principles in the modification, development and production of projects

IND5-5 selects, interprets and applies a range of suitable communication techniques in the development, planning, production and presentation of ideas and projects

IND5-1 identifies, assesses, applies and manages the risks and WHS issues associated with the use of a range of tools, equipment, materials, processes and technologies

IND5-3 identifies, selects and uses a range of hand and machine tools, equipment and processes to produce quality practical projects

IND5-9 describes, analyses and uses a range of current, new and emerging technologies and their various applications

Assessment Components

A. End Table Design Folio

B. Practical Production Progress

A. End Table Design Folio

1. Cover Page

Students are to produce a cover page for their assessment task. This should include the student's name, class and teacher as well as an image of the student's project.

2. Statement of Intent

Students are to write a *Statement of Intent* which includes the following points:

- A specific and detailed statement of **what** is to be constructed, **where** and **how** it is to be done, **why** this project needs to be made and **who** will use the finished product.
- List and explain the **limitations** for the project.

This section should be approximately **1 page** in length.

3. Research

Students are to research at least **4** existing End Table designs. For each design researched the following points should be included:

- A **clear image** and a **reference** as to where it was found. This can be achieved by simply copying the URL address (if found on the internet) or source in small text below the image.
- A **PMI** for each design stating the **positive** elements of the design, the negative (or **minus**) elements and the **interesting** elements of the design.

To ensure image quality, each researched design should be **no smaller than ½ page each**.

4. Sketching

Students are to produce at least **4** neat and presentable hand sketches of the End Table project. Sketches should:

- Be produced by **hand**, **neat** and at a **presentable standard** using **pencil** or **markers**.
- All sketches need to include **annotations**.
- Sketches can include detail drawings of **specific components** of the projects e.g. joints.

- High quality sketches will include details such as **grain direction** and may even include **colour** if applicable.

To ensure the quality of sketches, each sketch must be **no smaller than ½ page each**.

5. CAD

Students are to produce at least **4** images of the End Table project using **CAD** (Computer Aided Design). These images are to be produced by:

- Access **Onshape** by visiting <https://www.onshape.com/> , click **Request Trial** button at the top right hand of screen and set-up your free account.
- Onshape works best when used on **Google Chrome**.
- Learning to use Onshape is completed through student centred learning and can be achieved in a way that best suits the learner. Students can use:
 - The printed tutorial titled **Workshop 1 An Introduction** provided to all students and time allocated to complete in class (further copies can be obtained from your teacher). This tutorial will provide all the skills necessary to complete this section of the assessment.
 - Click the **Learn** tab at the top of the Onshape homepage and follow the links.
 - Access **YouTube** and view the countless tutorials available.
- The CAD images must be true representations of the project with accurate **dimensioning**.
- Each CAD image presented must be from a **different view** of the project and must serve to highlight the workmanship of the student.
- Each image must contain a **unique identifying feature** built into the image e.g. an initial, a basic shape etc. This will be used to affirm that it was the student's own work and any without this identifying feature built-in run the risk of being suspected of plagiarism.

Each CAD image must be presented as **1 image to a page**.

6. Presentation

The End Table Design Folio must be presented:

- A computer generated document using **Times New Roman** (or similar) size **12** font, **1.5** spacing (headings may be formatted in any font).
- **Printed** (colour is preferred) and presented with **1 staple** at the top left hand **corner** of the document.

End Table Design Folio Marking Criteria

	Outstanding	High	Sound	Basic	Limited	Marks
Statement of Intent	Clarifies the intent of the project by explaining clearly what is to be achieved and why	Clarifies the intent of the project by explaining what is to be achieved and why	Gives a brief description of what is to be achieved and why	Gives a brief or incomplete description of what is to be achieved	Gives an incomplete description of what is to be achieved	/5
Research	Describes a wide range of research conducted, which is relevant to the intent of the project	Describes research conducted, most of which is relevant to the intent of the project	Describes research conducted, some of which is relevant to the intent of the project	Minimal reference to appropriate research conducted.	Appropriate research not evident.	/5
Sketching	Demonstrates a wide range of sketching techniques, appropriate to the development of the project	Demonstrates a range of sketching techniques most of which are appropriate to the development of the project	Demonstrates some sketching techniques, appropriate to the development of the project	Demonstrates few sketching techniques, which are appropriate to the development of the project	Minimal evidence of sketching techniques that relate to the development of the project	/5
CAD	Creates dimensionally accurate CAD images that comprehensively describe the project	Creates dimensionally accurate CAD images that describe the project	Creates CAD images that describe the project	Creates CAD images that resemble the project	CAD is not attempted and/or incomplete	/20
Presentation	All presentation criteria are met	Most presentation criteria are met	Some presentation criteria are met	A presentation criteria has been met	Presentation criteria has not been met	/5
						/40

B. Practical Production Progress

The practical project will be marked on the quality of **techniques** displayed and evident in the project, the competent **use of tools and machinery**, the **understanding of timber** as a resource evident through selections and choices made during the construction process, the level of student **progress** in relation to the class and the student's ability to **work safely** in a workshop environment.

Practical Production Progress Marking Criteria

	Outstanding	High	Sound	Basic	Limited	Marks
Techniques	Demonstrates very high quality in all aspects of the project production	Demonstrates high quality in most aspects of the project production	Demonstrates substantial quality in most aspects of the project production	Demonstrates basic quality in most aspects of the project production	Demonstrates poor quality in all aspects of the project production	/15
Tools and Machinery	Competently applies and uses a wide range of appropriate industrial processes in the production of the project	Competently applies and uses appropriate industrial processes in the production of the project	Applies and uses some industrial processes in the production of the project	Applies and uses a limited range of common industrial processes in the production of the project	Applies basic processes in the production of the project	/15
Timber Working Knowledge	Competently applies and uses a deep working knowledge of timber in the production of the project	Competently applies and uses a good working knowledge of timber in the production of the project	Applies and uses a limited working knowledge of timber in the production of the project	Applies and uses a limited working knowledge of timber in the production of the project	Makes inappropriate choices due to a poor working knowledge of timber in the production of the project	/10
Progress	Progression of project is at such a stage that the project will be completed to a high standard with all initially intended features	Progression of project is at such a stage that the project will be completed to a high standard but without all initially intended features	Progression of project is at such a stage that the project will be completed but not to the standard initially intended and without all initially intended features	Progression of project is at such a stage that the project is at risk of being not completed or completed to a poor standard and without many initially intended features	Progression of project is at such a stage that the project is at risk of being not completed	/10
WHS	Uses of a wide range of appropriate safe working practices	Uses some appropriate safe working practices	Has used one or two appropriate safe working practices	Has difficulty demonstrating basic safe working practices	No evidence of safe working practices demonstrated.	/10
						/60

Appendix

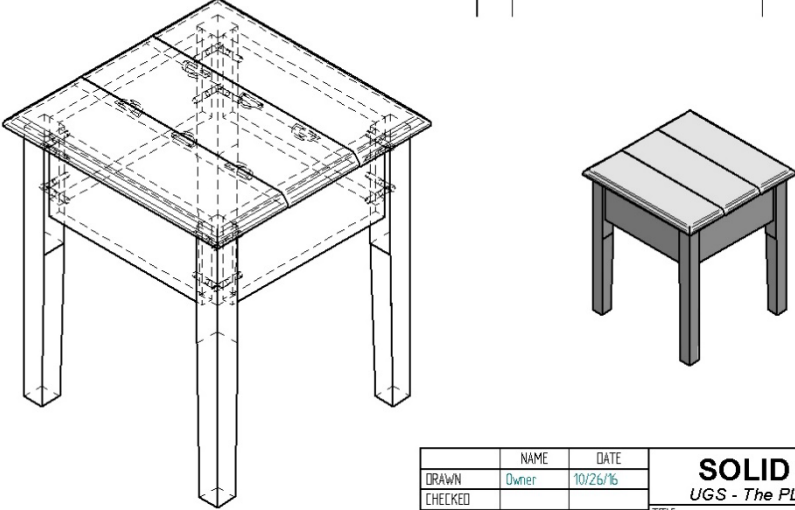

Exploded view of a table showing the top, legs, and internal structure. A perspective view of the assembled table is shown to the right.

REVISION HISTORY			
REV	DESCRIPTION	DATE	APPROVED

	NAME	DATE	SOLID EDGE	
DRAWN	Owner	10/26/16	UGS - The PLM Company	
CHECKED			TITLE	
ENG APPR			Table Full asm	
MGR APPR			SIZE	DWG NO
UNLESS OTHERWISE SPECIFIED DIMENSIONS ARE IN MILLIMETERS ANGLES +XX° 2 PL #XXX 3 PL #XXXX			A4	
			FILE NAME	Yr 10 table full asm.dft
			SCALE	WEIGHT: SHEET 1 OF 1

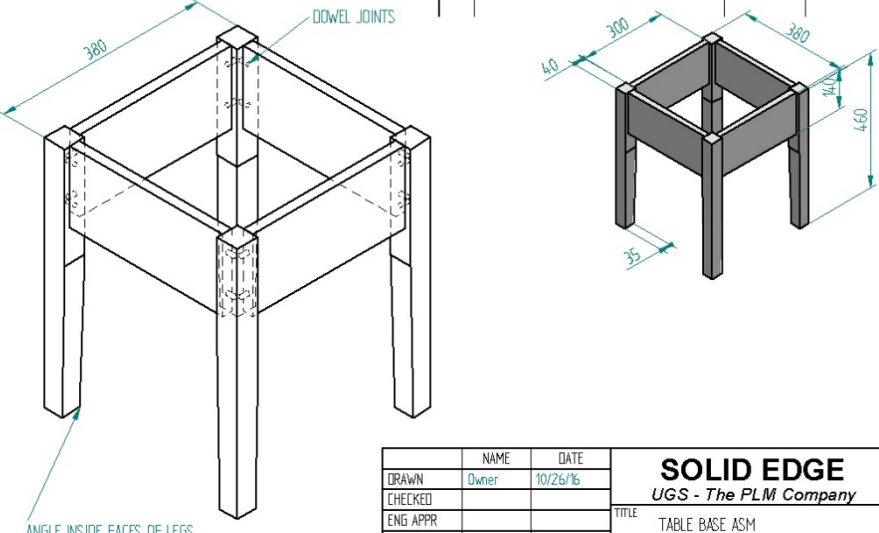

Exploded view of a table base with dimensions. A perspective view of the assembled base is shown to the right with dimensions. Labels include 'DOWEL JOINTS' and 'ANGLE INSIDE FACES OF LEGS'.

Dimensions for the perspective view: 300 (width), 380 (depth), 460 (height), 40 (leg thickness), 35 (leg width).

REVISION HISTORY			
REV	DESCRIPTION	DATE	APPROVED

	NAME	DATE	SOLID EDGE	
DRAWN	Owner	10/26/16	UGS - The PLM Company	
CHECKED			TITLE	
ENG APPR			TABLE BASE ASM	
MGR APPR			SIZE	DWG NO
UNLESS OTHERWISE SPECIFIED DIMENSIONS ARE IN MILLIMETERS ANGLES +XX° 2 PL #XXX 3 PL #XXXX			A4	
			FILE NAME	TABLE BASE.dft
			SCALE	WEIGHT: SHEET 1 OF 1

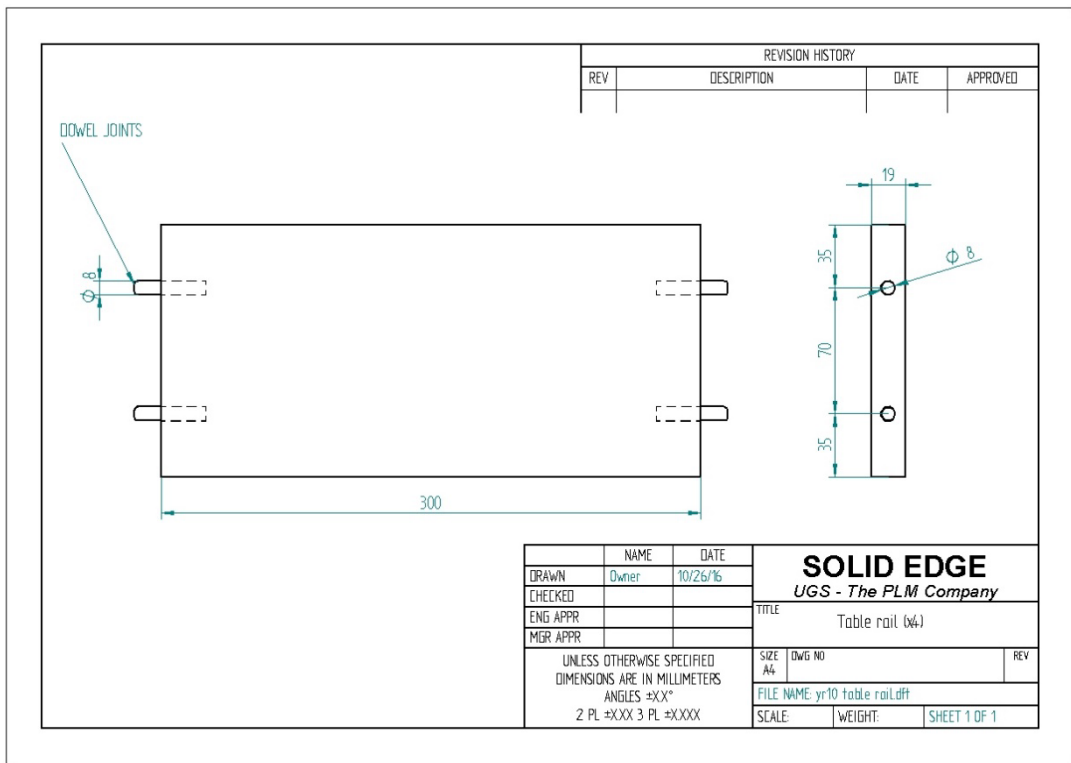
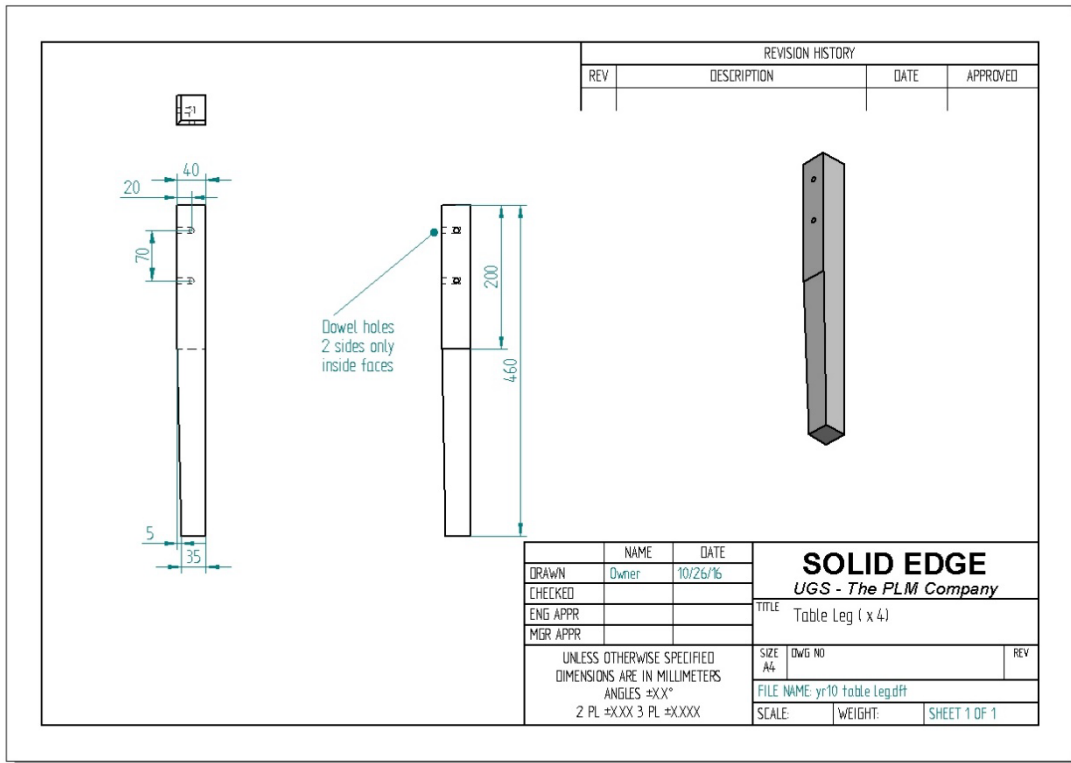

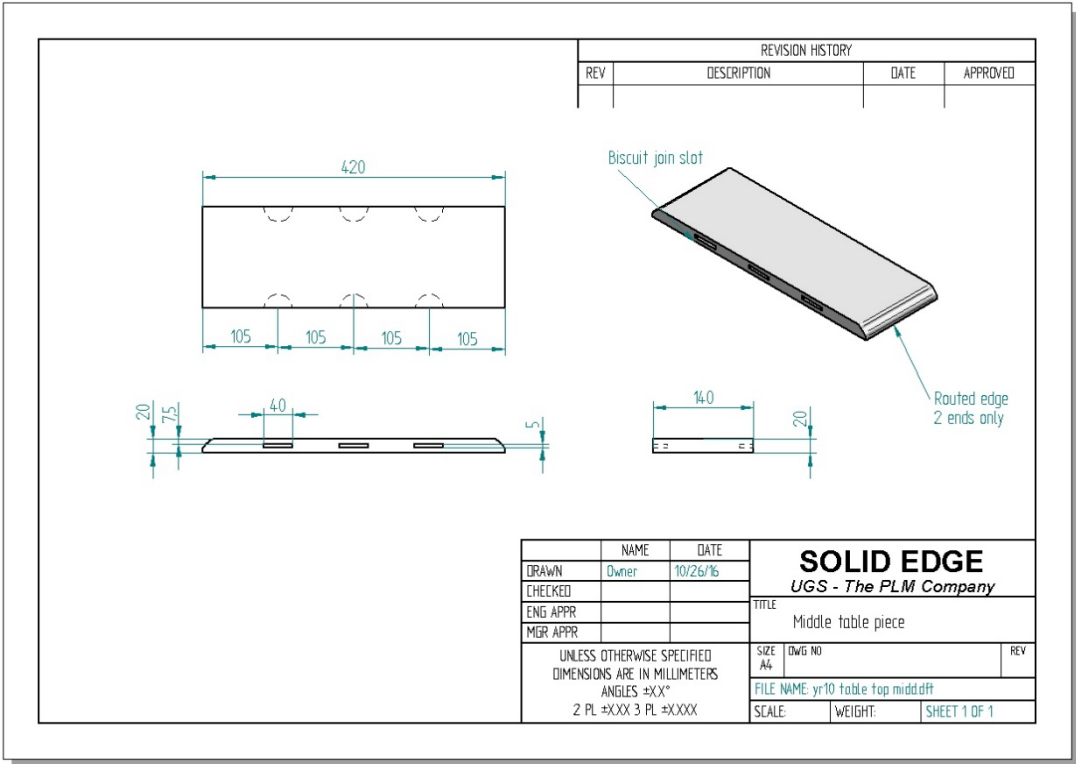
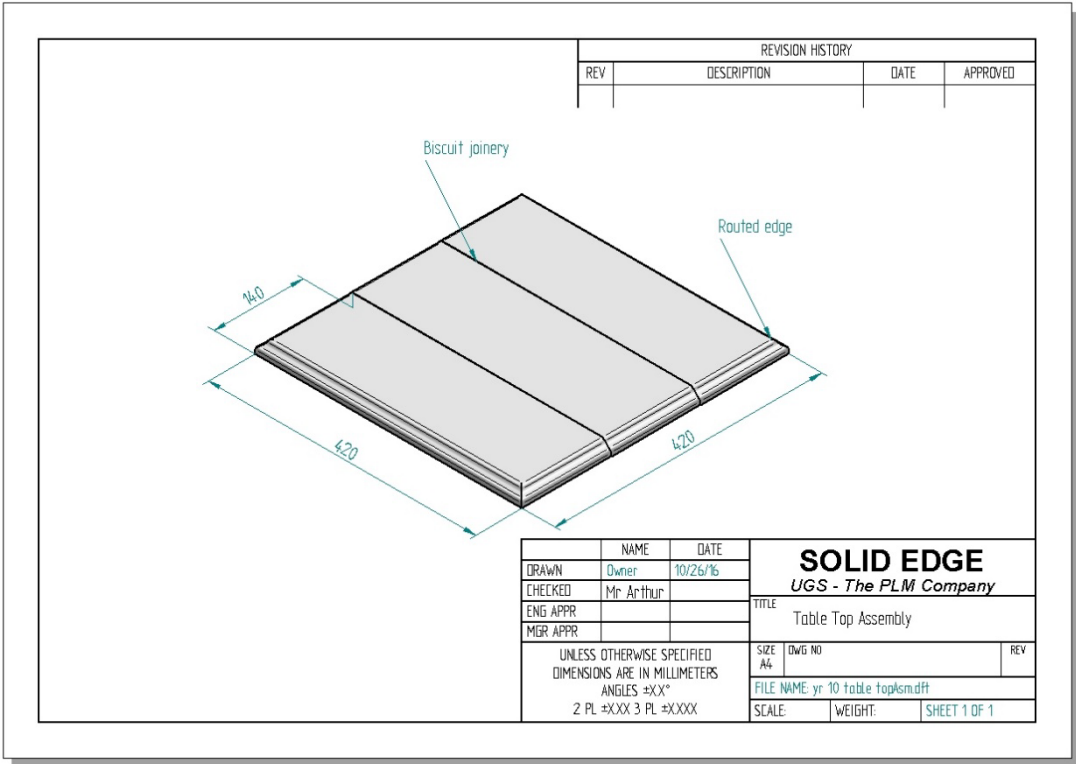

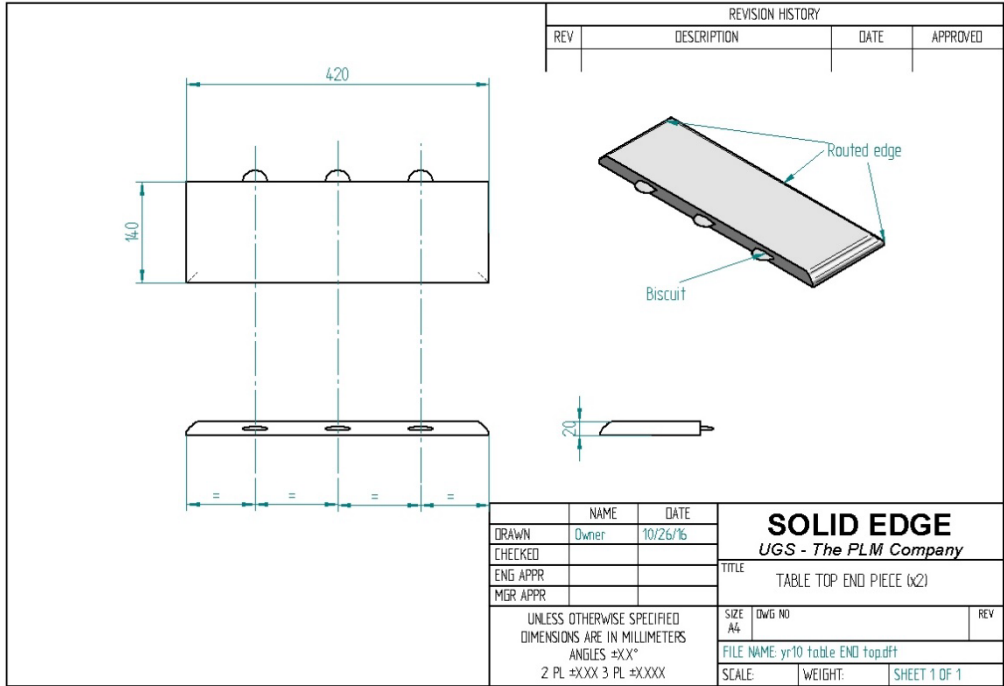

REVISION HISTORY			
REV	DESCRIPTION	DATE	APPROVED

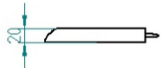
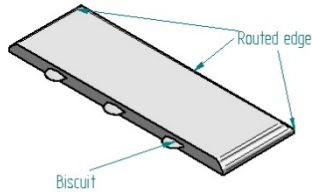
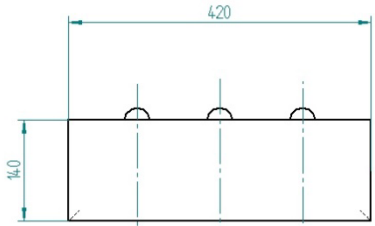

	NAME	DATE
DRAWN	Dwner	10/26/16
CHECKED		
ENG APPR		
MGR APPR		

SOLID EDGE		
<i>UGS - The PLM Company</i>		
TITLE		
TABLE TOP END PIECE (x2)		
SIZE	DWG NO	REV
A4		
FILE NAME: yr10 table END top.dft		
SCALE:	WEIGHT:	SHEET 1 OF 1

UNLESS OTHERWISE SPECIFIED
 DIMENSIONS ARE IN MILLIMETERS
 ANGLES ±X.X°
 2 PL ±XXX 3 PL ±XXXX